

AMP HOUR METERS PUMP CONTROLLERS

MODELS - 290-AH1-DIN AMP HOUR TOTALIZER IN DIN PKG
290-AHP1-DIN AMP HOUR CONTROLLER IN DIN PKG

CONTENTS:

I. OVERVIEW FOR AMP-HOUR BASED METERS: P. 2

II. MODEL 290-AHP1-DIN MENU OPERATION: P. 3

- A. AH TOTAL SCREEN
- B. RESETTABLE SCREEN
- C. PRIME PUMP SCREEN
- D. PRESET1,2 SCREEN
- E. PRESET1,2 CNT LEFT SCREEN
- F. TIMER1,2 SCREEN
- G. TIMER1,2 CNT LEFT SCREEN
- H. CYCLE COUNT 1,2 SCREEN P. 4**
- I. SETUP SCREEN
 - 1. SHUNT SIZE SCREEN
 - 2. RELAY1 SCREEN
 - 3. RELAY2 SCREEN
 - 4. Rect: P-ON RESET SCREEN

III. INSTALLATION: P. 5

IV. TROUBLE-SHOOTING: P. 6

V. APPENDIX: P. 7-9

- A. CALCULATING THE PRESET AND TIMER VALUES
- B. PUMP SETTING WORKSHEET
- C. WARRANTY & TERMS OF SALE

REV. 09/07/12

CHECK FOR FREE MANUAL UPDATES AT www.jpotech.com

JP Tech, Inc. ▪ Box 863 ▪ 2286 Church Street, Unit C ▪ East Troy ▪ WI ▪ 53120
Phone (262) 642-7671 ▪ Fax (262) 642-7681

I. OVERVIEW FOR AMP-HOUR BASED METERS

JP Tech's Ampere-Hour meters incorporate several screen options in the Menu designed for ease of operation, information gathering, and programming. All models incorporate displays showing accumulated Ampere-Hours or Ampere-Minutes (for Amp Hour meters). A resettable Ampere-Hour/Ampere-Minute display is included. In addition, there is a "Shunt" display menu item used to select shunt size in hours or minutes and the millivolt input signal (50mV, 60mV, or 100mV).

All models use a two (2) button keypad to cycle through the Menu displays available and to set the parameters of the meter:

◆ The **SELECT** key, when pressed and released, cycles through the different screens available to the specific model. In all screens (except the AH TOTAL, SETUP and SPECIAL FUNCTION screens where applicable), holding the **SELECT** key for about 3 seconds will enable the flashing cursor; releasing and pressing again will position the cursor for a change to be made. *The **SELECT** key will not change any existing information. It only provides a way to move through the menu or move the flashing cursor.*

◆ The **CHANGE** key is used to change a value or option related to the specific display chosen with the **SELECT** key (for example RESETTABLE = VALUE and SHUNT SIZE = OPTION). NOTE: Pressing and releasing, **at any time**, BOTH the **SELECT** and the **CHANGE** keys together will take you back to the AH TOTAL default screen.

◆ HOW TO ENTER OR CHANGE DATA:

VALUES: RESETTABLE SCREEN: From the AH TOTAL screen, PRESS/RELEASE the **SELECT** key. This will bring you to the RESETTABLE screen. To enter any value or reset existing values, PRESS/HOLD the **SELECT** key for about 3 seconds until the *LEFT MOST DIGIT* begins to flash. When it flashes, release the **SELECT** key. If you want the digit that is flashing to stay the same, PRESS/RELEASE the **SELECT** key *ONCE*. This will move the flashing cursor over to the right one digit. **[This is the method used to move the flashing cursor over for all screens.]**

If you want to change the value of the flashing digit, PRESS/RELEASE the **CHANGE** key *ONCE*. Each time the **CHANGE** key is pressed and released, the value of the digit increases by one (1) and cycles from 0 through 9. **[This is the method used to change the value of the flashing cursor for all screens.]**

Once you have set the values you want, PRESS/HOLD the **SELECT** key until the flashing cursor disappears (about 3 seconds).

◆ DETAILED EXAMPLE:

OPTIONS: SHUNT SIZE: To select the appropriate shunt size and millivolt signal, PRESS/RELEASE the **SELECT** key until the SHUNT SIZE screen appears (for the TOTALIZER Model) or PRESS/HOLD the **SELECT** key at the **SETUP** screen (for the PUMP CONTROLLER model) for about 3 seconds until the SHUNT SIZE screen appears.

To change the SHUNT SIZE option, PRESS/HOLD the **SELECT** key until the flashing cursor appears just to the right of the "H". PRESS/RELEASE the **CHANGE** key to scroll through the amperage size options available until the correct one for your rectifier rating is shown. IE the millivolt default setting is correct (most rectifiers use a 50mV signal), PRESS/HOLD the **SELECT** key for about 3 seconds until the flashing cursor stops. Your new option has been set. PRESS/RELEASE the **SELECT** key at this point takes you to the next screen.

If the millivolt default setting is not correct, once you have located the correct amperage rating option, PRESS/RELEASE the **SELECT** key once to bring you over to the millivolt option. PRESS/RELEASE the **CHANGE** key will toggle between the 50mV and 100mV option. Once your amperage setting and the millivolt setting is correct, PRESS/HOLD the **SELECT** key for about 3 seconds until the flashing cursor stops. You have now locked in the new settings.

II. MODEL 290-AHP1-DIN MENU OPERATION

This model incorporates everything the Model AH-1 has plus it can support 2 pumps with associated Presets and Timers or one (1) pump and one (1) rectifier or two (2) rectifiers. All internal output relays are fused. Also, the status of the pump(s) will be indicated in each of the main display screens by either a **LmV** (Low Millivolt signal = no accumulation of Amp Hours and the pump(s) is off), **P1** (Pump 1 = ON), **P2** (Pump 2 = ON), or **P12** (both pump 1 and 2 = ON). A blank area here indicates that you are getting a mV signal but neither pump is on.

- A. To the right is the default display screen that shows the **CUMULATIVE AMPERE/HOUR – AMPERE/MINUTE TOTAL**. This display will appear when the meter is first energized and is the screen that will appear when BOTH the **SELECT** key and the **CHANGE** key are pressed and released at the same time when you are in the main menu. The **LmV** (Low Millivolt) appears in all screens when there is no millivolt signal coming to the meter from the rectifier.

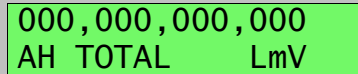

000,000,000,000
AH TOTAL LmV

NOTE: This value cannot be reset and is good up to one (1) trillion Amp/hours.

- B. To the right is the **RESETTABLE AMPERE/HOUR** screen. This display totals cumulative ampere/hours/minutes like the AH TOTAL screen but can be reset to zero at any time.

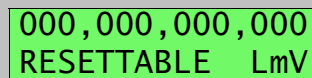

000,000,000,000
RESETTABLE LmV

Programming: See 'OVERVIEW'

- C. To the right is the **PRIME PUMP FUNCTION** screen. When the cursor is flashing, push/releasing the **SELECT** key will toggle between PUMP 1 and PUMP 2. Push/releasing the **CHANGE KEY** will engage/disengage the pumps. When a pump(s) is engaged, the LmV symbol will change to indicate which pump is on. You can engage both pumps at one time if you wish. **REMEMBER: THERE IS NO AUTOMATIC SHUT OFF ONCE THE PUMPS ARE ENGAGED.** You must either disable each pump before leaving this screen or when leaving this screen (push/hold the **SELECT** key for about 3 seconds), both pumps will be disabled



PRIME PUMP 1
DISABLED LmV

Programming: See 'OVERVIEW'

- D. To the right is the **PRESET1** screen. This screen is used to set the interval of Amp Hours before **TIMER 1** is activated. The **PRESET2** screen operates the same way for **TIMER 2**. [See "Calculating the Preset and Timer Value Needed" in the appendix to calculate these values.]

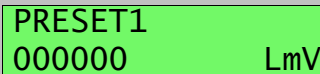

PRESET1
000000 LmV

Programming: See 'OVERVIEW'

- E. To the right is the **PRESET1 CNT LEFT** screen. This screen shows the amount of Amp Hour preset that is remaining before it activates the timer (see below). This screen is generally for information purposes only and does not need to be edited. The **PRESET2 CNT LEFT** screen operates the same way for Pump 2. [See "Calculating the Preset and Timer Value Needed" in the appendix to calculate these values.]

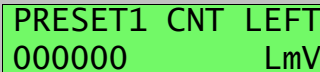

PRESET1 CNT LEFT
000000 LmV

Programming: See 'OVERVIEW'

- F. To the right is the **TIMER1** screen. This screen is used to set the time, in seconds, for Relay 1 to change states. When the **PRESET1 CNT LEFT** screen counts down to zero, the **TIMER1** value is activated and changes the status of **RELAY 1**. Values up to 999999 seconds (16,666 minutes or 11.6 days) are available. **TIMER2** for **RELAY 2** works the same way. [See "Calculating the Preset and Timer Value Needed" in the appendix to calculate your values.] **NOTE:** The relays will not change states until the **PRESET** counts down. At power up, the relays stay either **NO** or **NC** as marked unless the meter is powered down when **TIMER1 (2) CNT LEFT** still has counts.

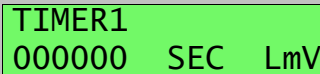

TIMER1
000000 SEC LmV

- G. To the right is the **TIMER1 CNT LEFT** screen. This screen shows the amount of seconds remaining during the "ON" pump condition. This screen can also be used to add time to the current pump cycle for a one time add without effecting the **TIMER1** setting. **TIMER2 CNT LEFT** for Pump 2 works the same way.

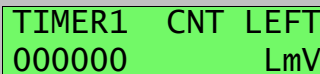

TIMER1 CNT LEFT
000000 LmV

Programming: See 'OVERVIEW'

III MODEL 290-AHP1-DIN MENU OPERATION (Cont.)

H. To the right is the **CYCLE COUNT1** screen. This screen shows the number of times the **PRESET1** and **TIMER1** have cycled through their counts. **CYCLE COUNT2** shows a similar value for **PRESET2** and **TIMER2**.

Programming: See 'OVERVIEW'

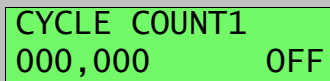

CYCLE COUNT1
000,000 OFF

I. To the right is the **SETUP** screen/menu. This screen provides access to menu items that usually need to be set only once or changed rarely. The **SHUNT SIZE, RELAY1, AND RELAY2** are Submenus of this screen.

Programming: See 'OVERVIEW'



SETUP

1. To the right is the **SHUNT SIZE** menu that is used to select the correct amperage value for the amperage of the rectifier, the choice of amp/hours or amp/minutes, and the millivolt output of the shunt. Selecting an amperage size with an 'H' causes the meter to accumulate Amp/Hours. Selecting a size with an 'M' causes the meter to accumulate Amp/Minutes. The millivolt option toggles between 50mV, 60mV, and 100 mV.

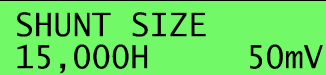

SHUNT SIZE
15,000H 50mV

2. To the right is the **RELAY1** submenu screen. This display allows you to **DISABLE** the output of relay #1, have it control a **PUMP**, or have it control a **RECTIFIER**. When first energized, the default setting is "PUMP" indicating that Pump 1 relay is enabled.

Programming: See 'OVERVIEW'



RELAY1
PUMP

3. To the right is the **RELAY2** screen. This screen operates the same as **RELAY1**. The default setting is "PUMP".

Programming: See 'OVERVIEW'



RELAY2
PUMP

4. When setting to "Rectifier" in the relay screen and "Enabling" this screen, the preset values (**PRESET** and **TIME**) are automatically reset to their programmed value each time the meter is powered up.

Programming: See 'OVERVIEW'



Rect P-ON RESET
DISABLED/ENABLED

REMEMBER: PRESSING/RELEASE, AT ANY TIME, BOTH THE SELECT KEY AND THE CHANGE KEY TOGETHER BRINGS YOU BACK TO THE AH TOTAL SCREEN.

III. INSTALLATION

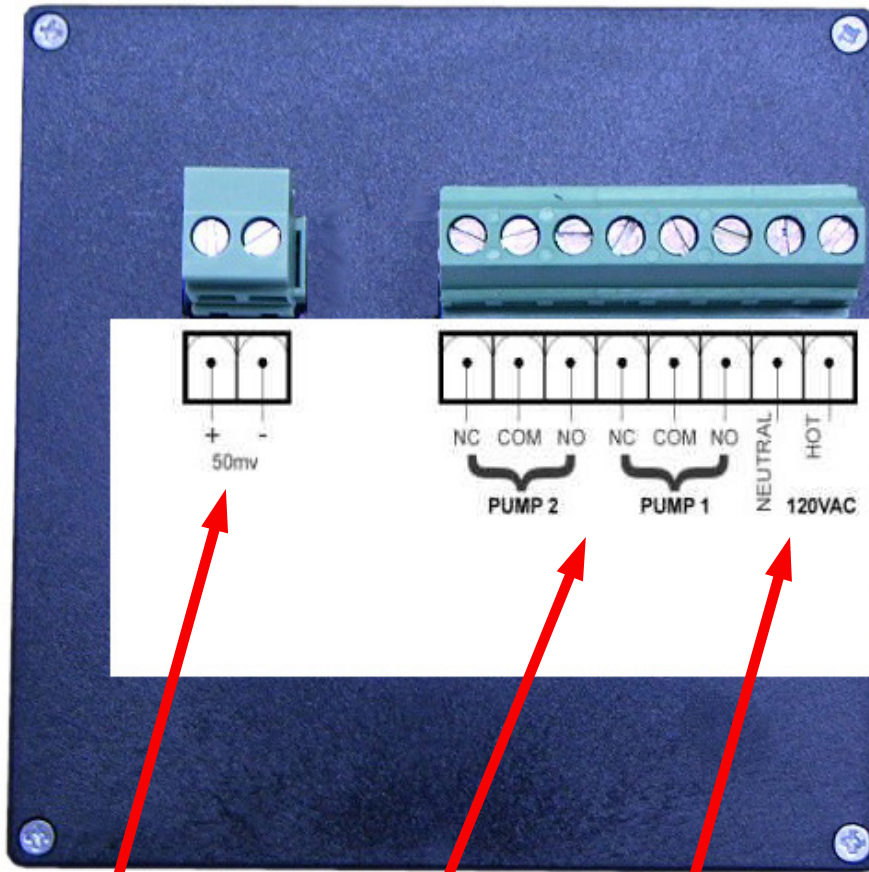

MILLIVOLT INPUT

Use a 22AWG red/black shielded twisted pair wire for the millivolt input. This wire can be connected either to the shunt or to the back of the ammeter. The red wire must be connected to the positive terminal (or most positive side of the shunt) and the black wire to the negative terminal (or most negative side of the shunt).

DO NOT CONNECT THE BRAIDED WIRE OR SHIELD TO GROUND!

PUMP OUTPUT

(Only in Pump Control Versions)

Any 220 VAC pump which draws no more than **five amps** can be wired into these receptacles. To make receptacle "hot" jump the "com"s together and connect them to the 'Hot' AC in. Wire the pump to either NC or NO and Neutral.

In rectifier control, do nothing and the relays will be "dry contact" relays.

120 VAC POWER

The meter operates off 120 VAC. Optional: 220VAC

WARNING:

All board components and circuitry are common to mV signal and must remain isolated from all other circuits and grounds. This is only an issue if board is removed

IV.TROUBLESHOOTING FOR AMP HOUR BASED METERS

AMP HOUR ISSUES:

NO AMP HOURS RECORDING WHEN RECTIFIER IS ENGAGED.

May have the leads from the twisted pair mV wire connected wrong at the shunt or analog amp meter in the remote. Reverse the leads of the Twisted Pair mV wire on the shunt or analog amp meter. [Red = positive, Black = negative]

AMP HOURS BEING RECORDED AT A VERY FAST RATE.

May have the Twisted Pair mV wire connected to Voltmeter rather than the analog amp meter. Disconnect and reconnect to the amp meter.

AMP HOURS COMING IN TOO SLOW OR TOO FAST FOR WHAT WE ARE USE TOO.

May have the wrong "SHUNT SIZE" setting for the size of the rectifier / shunt the meter is connected too. Go to the "SHUNT SIZE" screen (see Manual) and make sure the correct shunt size is entered.

PUMP ISSUES:

PUMP(S) STAY ON ALL THE TIME.

May be due to the Preset amp hours coming in quicker than the Timer settings have a chance to time out (the timer will re-set to start value each time preset reaches it's set mark). Make sure calculations for feed rate is correct. May need a bigger pump or, if using our double peristaltic model, use both pumps together.

PUMP(S) WON'T ENGAGE WHEN TIMER TIMES OUT OR WHEN ACTIVATED IN "PRIME PUMP" SCREEN.

May have blown the 5A fuse protecting the relays. Open lid of controller and check the fuse for continuity. (Unplug unit while doing this step.)

If fuse is OK, engage the relay in "Prime Pump" screen and check for 110VAC out of the receptacle with a DMM meter. If there is 110VAC, the pump controller is OK and you need to check the pump and it's connection.

PERISTALTIC PUMPS DON'T PUMP AS MUCH AS THEY DID IN THE SAME AMOUNT OF TIME.

May be due to squeeze tubes that have deteriorated to point that they can't re-expand after being compressed. They need to be replaced.

STROKES (AH-PMP-2 MODELS) ARE NOT BEING RECORDED WHEN PUMP IS ENGAGED.

First you need to determine where the problem is located. Place the controller in the "MANUAL PUMP" mode and carefully take a jumper and, intermittently, go across terminal #9 & #10 for Stroke 1 and terminals #9 & #11 for Stroke 2. If strokes are recorded in the Manual Pump screen for each stroke pump, the controller is working fine. The problem may be with the signal coming from the pump to the controller. Please call your source to get suggestions on how to fix this problem. If NO strokes are recorded in the Manual Pump screen, than the controller is not recording the signal. Please call your source of this meter for directions for repair.

APPENDIX

A. CALCULATING THE PRESET AND TIMER VALUES NEEDED:

The values you may need to run your metering system correctly can vary significantly. In most cases, the calculations are straightforward and only require a ratio of need chemical additions per amp/hour units. The following is a step-by-step example of how to derive a series of options for an actual situation. The user's chemical representative should have supplied the feed ratio for chemical per amp/hour.

Step 1. Determine Desired Feed Ratio:

Nominal Feed Ratio Desired: 1 gallon per 18,000 amp/hours
(supplied by chemical representative)
Metric: 3784 ml (1 gallon) per 18,000 amp/hours

Step 2. Determine the ratio of feed rate per amp/hour count. Divide the ml by amp/hours.
 $3784\text{ml} / 18,000 \text{ amp/hours} = 0.21 \text{ ml per 1 amp/hour}$

Step 3. Determine the hourly maximum desired feed ratio. Use the shunt size to calculate this.
 $0.21 \text{ ml per amp/hour count} \times 6000 \text{ amp shunt} = 1260 \text{ ml per 6000 amp/hours}$

Step 4. Determine actual pump flow rate. The flow rate should be calculated for one minute. Use a measured container to gather this information. If using a pulse type pump, try to remain at 100% stroke and a 100% rate for maximum accuracy.
Pump rate measured: 32 ml per minute
Multiply by 60 minutes: 32 ml X 60 = 1920 ml per hour

Step 5. Determine the feed rate multiplier. Divide the desired feed rate (from Step 3) by The actual feed rate (from Step 4) to obtain the feed rate multiplier.
 $1260 \text{ ml per 6000 amp/hours (Step 3)} / 1920 \text{ ml per hour (Step 4)} = 0.66$
Note: If your multiplier is greater than one, your pump is too small for the Desired feed rate!

Step 6. Determine pump ON time. Multiply the feed rate multiplier (Step 5) by 3600 seconds.
 $0.66 \text{ (Feed Rate Multiplier)} \times 3600 \text{ seconds} = 2376 \text{ seconds}$
Note: This is the duration the pump must remain ON during one hour to pump the desired amount of chemical.

Step 7. Calculate and select the final settings.
Every 6000 amp/hours the pump will turn on for 2376 seconds (step 6)
Note: THIS IS YOUR FINAL RATIO.

***** Break Down the Ratio to a Usable Level *****

When rounding seconds, **always go down to the next lowest whole second** (e.g.; 50.9 sec. = 50 sec; 50.1 sec. = 50 sec.) When rounding amp/hours, **always round up to the next whole amp/hour** (e.g.; 50.9 = 51; 50.1). This practice will ensure that your meter is adding less rather than too much chemical.

Find the smallest seconds setting:

Ratio:	6000 amp/hours	:	2376 Seconds
Round Down:	6000	:	2376
Difference:	0	:	0
% Error:	0%	:	0%

Dividing by 10 =

Ratio:	600.0 amp/hours	:	237.6 Seconds
Round Down:	600.0	:	237
Difference:	0	:	-0.6 Seconds
% Error:	0	:	-0.25%

Dividing by 10 =

Ratio:	60.00 amp/hours	:	23.76 Seconds
Round Down:	60.00	:	23
Difference:	0	:	-0.76
% Error:	0	:	-3.30%

Keep Seconds and Correct for Error =

Ratio:	60.0 amp/hours X [1-0.033(% error)]	:	23 Seconds
New Ratio:	58.02	:	23
Round Up:	59	:	23
Difference+0.98		:	23
% Error	1.67%	:	0.0

Our final setting will be for every 59 amp/hours the pump must run for 23 seconds. Every 18,000 amp/hours (from step 1) you will need to add 63 ml (3784 ml X 0.0167) to correct for the 1.67% error.

B. PUMP SETTING WORKSHEET

You will need the following information to use the Pump Settings Worksheet:

Nominal Feed Ratio: (A) _____ Gal. Per (B) _____ Amp/Hours
(As recommended by your chemical representative)

Shunt Size: (E) _____ Amps
Actual Pump Vol: (G) _____ ml. Per minute (Measured by You)

Step 1. Nominal Feed Ratio:
(A) _____ GAL. Per (B) _____ Amp/Hours

OR (C) _____ ml. Per (B) _____ Amp/Hours
[3784ml = 1 gallon]

Step 2. Feed Ratio per Amp/Hour:

_____ ml/ _____ Amp/Hour = (D) _____ ml/1 Amp/Hour
(C) (B) (C)/(B)

Step 3. Desired Feed Rate:

_____ ml per 1 Amp/Hour X (E) _____ Amps = (F) _____ ml/Hour
(D) (Shunt Size) (D) X (E)

Step 4. Measure Actual Pump Rate Per Minute:

(G) _____ ml per Minute X 60 Minutes = (H) _____ ml per Hour
(Pump Volume) (G) X 60

Step 5. Feed Rate Multiplier (Desired Feed Rate / Actual Feed Rate):

_____ ml per Maximum Amp/Hour / _____ ml per Hour = (I)
(F) (H) (F/H)

Step 6. Pump ON Time per Hour:

_____ X 3600 Seconds = (J) _____ Seconds
(I) (I) X 3600

Step 7. Final Settings:

Every _____ Amp/Hour, the pump must turn ON for _____ Seconds
(E) (J)

Ratio: _____ : _____
Round _____ : _____
Diff: _____ : _____
%Error _____ : _____

JP TECH, INC.

LIMITED PRODUCT WARRANTY

JP Tech warrants to first user of each new JP Tech product or component that it is free from defect in material and workmanship. The obligations of JP Tech under this warranty are expressly limited to the following:

- JP Tech will repair or replace, at its option, any defective components for a period of twelve (12) months from date of shipment. No charges are covered for the removal or replacement of defective components.
- This warranty applies only if the product is defective under normal use. It does not apply to breakage or defect from accident, alteration, misuse, or abuse of the product or component. In addition, this warranty is effective only if the product or component is installed in a location and manner prescribed by JP Tech's instructions and only if it is so maintained. This warranty becomes null and void if the product or component is altered by anyone other than JP Tech, its authorized representatives, or by expressed written authorization for a specific situation.
- If JP Tech elects to send a service technician to a customer site to repair a defect, the cost of transportation and/or living expenses will be paid for by the customer. Should the defect turn out to be the result of the customer's misuse, improper installation, or maintenance of the product or component, the customer will be responsible for the full cost of the service call including labor charges plus the aforementioned travel and living expenses.
- JP Tech will repair or replace any defective part within a product at the sole discretion of JP Tech. If JP Tech should choose to supply a part to the customer as a no-charge warranty replacement, the customer assumes all cost of installation associated with the replacement part. If the product needs to be returned for warranty service, a Returned Material Authorization (RMA) must be issued by JP Tech prior to such return. All returned material must be sent freight prepaid or it will not be accepted by JP Tech irrespective of warranty issues.
- There are no implied warranties of merchantability or of fitness for a particular purpose. The above warranty is made in lieu of all other guarantees or warranties, express or implied. JP Tech distributors or OEMs who purchase JP Tech products for resale are not authorized to assume any other obligation or liability for JP Tech.
- JP Tech will in no case or under any circumstances be liable for special, incidental or consequential damages, loss of profit or commission for any loss caused by any delay in production or shipment of product, or defect of any kind in any product or component covered by the sale. Without limitation, JP Tech will not be so liable with respect to furnishing of any product, or component, delay in such furnishing, use, resale, or other cause. JP Tech's liability arising out of the supply of any product or component, its use, resale or other disposition, or out of any guarantee or warranty, express or implied, or any other cause, shall in no way exceed the cost to JP Tech of the product or component which JP Tech agrees to repair or replace. JP Tech's liability for any product or component terminates upon expiration of the applicable repair or replacement period.

This implementation of this warranty may, under separate agreement, be subrogated to exclusive distributors or manufacturers who shall assume all or portions of the liability associated with warranty costs.

This warranty may be modified, wholly or in part, at any time by JP Tech without notice to past or future customers. The warranty revision in effect at the time of shipment shall prevail in any claims rendered.

JP TECH, INC.

TERMS AND CONDITIONS OF SALE

The purchase of any products or services supplied by JP Tech shall be governed by the terms of this agreement. Purchaser of these products and services acknowledges and agrees to these terms without modification by any competing document or any agreement not reduced to writing and authorized by an officer of JP Tech, Inc.

- Pricing is the effective price at the time of the order. If the shipment of product is postponed by buyer, the price may be changed to reflect any price changes enacted by JP Tech. Prices may be changed by JP Tech at any time for any reason without notice to purchaser except for accepted orders not affected by a purchaser initiated delay. Prices, unless otherwise stipulated, do not include shipping and handling charges.
- Certain products may require initial and progress payments before the commencement and continuation of design, engineering, component procurement, and manufacture. These products will not be shipped until all progress payments have been made. Cancellation of any orders in progress will necessitate the forfeitures of any payments received to date as well as payment of any costs accrued in excess of paid amounts.
- Orders must be accepted by JP Tech at their home office. Acceptance of any purchase order, regardless of the method, is conditioned on assent of buyer to the terms and conditions contained herein.
- Sales are FOB point of shipment. Sales terms are net 30 days from date of shipment. Present or future sales, use, or other taxes on sales, installation or use shall be paid by purchaser. Purchaser shall pay 1% interest per month on all outstanding amounts due to JP Tech. Interest accrual shall begin on the 31st day after shipment for all outstanding amounts.
- All sales are final. Any decisions to accept return of product after shipment and receipt by purchaser shall be at the sole discretion of JP Tech and not until payment has been made and agreement by purchaser to pay all shipping, cancellation, and restocking charges that may accrue.
- Shipping dates given prior to shipment are estimated, actual delivery will be based on factory and engineering loading at the time of manufacture as well as the availability of parts required for manufacture. JP Tech shall not be liable for any costs or damages arising out of or related to any delays in shipment or delivery, including but not limited to liquidated damages, unless otherwise agreed in writing.
- JP Tech may change design or construction of any product or component in any way they see fit. Upgrades for previously purchased products may be available for certain products for a price that will be determined when appropriate.
- Except as provided herein, any controversy, claim or dispute arising out of or related to any order or sale or breach thereof, including but not limited to any breach of warranty claims, shall be litigated in state court, Walworth or Waukesha Counties, Wisconsin, and shall be governed by the laws of Wisconsin. If JP Tech is the prevailing party, JP Tech shall be entitled to collect all reasonable fees and costs, including court costs and attorney fees.